

Teledyne DALSA Rad-icon 2022

Detector User Manual
CameraLink Model



December 30, 2015

www.teledynedalsa.com/ndt



© 2015 Teledyne DALSA. All information provided in this manual is believed to be accurate and reliable. No responsibility is assumed by Teledyne DALSA for its use. Teledyne DALSA reserves the right to make changes to this information without notice. Reproduction of this manual in whole or in part, by any means, is prohibited without prior permission having been obtained from Teledyne DALSA.

About Teledyne DALSA

Teledyne DALSA is an international high performance semiconductor and electronics company that designs, develops, manufactures, and markets digital imaging products and solutions, in addition to providing semiconductor products and services. Teledyne DALSA's core competencies are in specialized integrated circuit and electronics technology, software, and highly engineered semiconductor wafer processing. Products and services include image sensor components; electronic digital cameras; X-ray detectors; vision processors; image processing software; and semiconductor wafer foundry services for use in MEMS, high-voltage semiconductors, image sensors and mixed-signal CMOS circuits.

Contact Information

Please feel free to contact the global TD-PI sales office for ordering, obtaining more detailed information or in case you encounter any problem when operating the detector:

Teledyne DALSA – Rad-icon Imaging

3400 Garrett Drive
Santa Clara, CA 95054
USA

Tel: +1 408 736 6000

Fax: +1 408 736 6001

E-mail: sales.rad-icon@teledynedalsa.com

Website: <http://www.teledynedalsa.com/ndt>

Contents

- System Precautions and Safety _____ 5
 - Safety Information 5
 - EMC compliance 6
 - System precautions 7
 - Detector Maintenance 8
- The Rad-icon Detector _____ 9
 - Detector highlights 9
- Setting up the Detector _____ 10
 - Detector Connectors and Cables 10
 - Setting up the Detector 14
 - Camera Link frame grabber card 14
 - Ground the detector 14
 - Connect trigger cable 14
 - Connect Camera Link cable 14
 - Connect power cable 14
 - Software Installation 14
- Installing the Rad-icon Detector _____ 15
 - Installing 15
 - Operating Systems Support 15
 - Obtain software 15
 - Sapera LT and CamExpert Installation 15
 - Camera Link frame grabber configuration files 16
 - Connecting 17
 - Communication 17
 - Acquiring Images 18
- Functional Description _____ 21
 - Operation modes 21
 - User Mode 21
 - Maintenance 21
 - Production 21
 - Full Well selection 21
 - Readout modes 22
 - X-ray source 22
 - Detector operation with pulsed X-ray source 22
 - Detector operation with DC X-ray source 23
 - Readout modes 23
 - Synchronization modes 24
 - Free running mode, Full Field of View 24
 - External trigger mode, Full Field of View 25
 - Snap shot mode 26
 - Shuttering 27
 - Diagnostics 28

Test Image.....	28
Firmware version, Model name and serial number	28
Power saving.....	29
Commands	30
Help.....	31
Identification	32
Get Detector Parameters.....	32
Get Detector Manufacturers Name	32
Get Detector Model Name.....	33
Get Detector Serial Number	33
Detector Firmware Version.....	34
Detector Operation Mode.....	35
Set Detector Mode.....	35
Get Detector Mode	35
Detector Power Mode	36
Set Detector Power Mode	36
Get Detector Power Mode	36
Source of Image Data	37
Set Source of Image Data	37
Get Source of Image Data.....	38
Full Well Selection.....	39
Get Full Well	39
Detector Synchronization Mode.....	40
Set Detector Synchronization Mode	40
Get Detector Synchronization Mode	40
Detector Readout Mode.....	41
Set Detector Readout Mode.....	41
Note: Command only available in PRODUCTION MODE.....	41
Get Detector Readout Mode	41
Set Detector Binning Mode	42
Get Detector Binning Mode	42
Extended Exposure / X-ray Window time	43
Set Extended Exposure Time.....	43
Get Exposure Time.....	43
Offset.....	44
Set Offset.....	44
Get Offset	44
Dark Current after Extended Standby.....	45
Mode switches	45
Error Handling.....	45
Mechanical Interface	46
Appendix A	47
Revision History	47

1

System Precautions and Safety

Safety Information

Definitions

User of the products as described in this manual is the Original Equipment Manufacturer (OEM) that is developing and producing an X-ray imaging device (or ‘modality’), using the product as an component to capture image information;

End-User of the products as described in this manual is the professional operating the OEM equipment to perform a diagnostic imaging routine;

Intended Use

The products as described in this manual are components that are used enclosed inside a User’s system to capture images in X-ray modalities. Typical applications include, but are not limited to, Non-Destructive Testing, Electronics Inspection and Computed Tomography (CT).

Installation Warning

The User is responsible for the safe and prudent installation of the detector in their system. All X-ray sources and controls, shielding, personnel safety monitoring devices, and personnel safety precautions and training involved in the use of this equipment are the responsibility of the User and/ or End-User.

Safety Statement

The general safety precautions that follow must be observed during all phases of installation, operation, service, repair and disposal of this system. Failure to comply with these precautions, or with specific warnings noted in this manual, violates the safety standards of design, manufacture and the intended use of this system.

Teledyne DALSA assumes no responsibility for the user’s failure to comply with these requirements.



Warning: The product, when installed, is subject to exposure from X-rays during operation.

To ensure personnel and patient safety, it is necessary that a radiation meter will be used to check for radiation leakage after installation of the digital camera in the user’s system.

For safety reasons, the on-time of the X-ray source should never be controlled directly by the detector synchronization output. Control of the X-ray source remains a system/ host responsibility.

Teledyne DALSA assumes no responsibility for proper installation of the detector, installation of X-ray shielding, X-ray shield enclosure testing, or safe and prudent operation of the camera system in the End-user's installation. It is the Users and End-users responsibility to ensure that local and federal guidelines regarding the installation and operation of X-ray sources are followed.

The power requirements of the product, especially the voltage specifications, must be strictly adhered to or the warranty will be void.

No User Serviceable Components

There are no components in this system which need to be replaced, modified, or adjusted by the (End-)User. Please contact Teledyne DALSA Support for assistance if needed.



Safety Warning: Tampering with this product voids the warranty and may degrade the detectors image quality and reliability, resulting in a possibly unsafe condition for (End-)User or Patients.

The system has been designed to minimize the amount of electromagnetic interference it may generate in a medical installation. This equipment generates and can radiate radio frequency energy and, if not installed and operated in accordance with the instructions, may cause harmful interference to other devices in the area.

Stacking

Teledyne DALSA recommends that the user does not stack the product or use it adjacent to other equipment. If this arrangement is unavoidable, then the (End-)user must ensure that there is adequate airflow around the detector and that normal operation conditions are maintained.

Disposal of Product

The detector contains lead and no batteries. Dispose the unit in accordance with local regulatory guidelines.



EMC compliance

To ensure EMC compliance, follow these specific guidelines:

- Ensure that all cable shields have a 360° electrical connection to the connector.
- Tightly fasten and secure all connectors.

Warning

- The detector can influence the performance of very sensitive equipment.
- Strong EMC disturbances can influence the detector's performance.

System precautions

The following precautions must be observed in order to prevent possible damage to your Teledyne DALSA Detector system:

Warning:

The use of accessories, power supplies and cables other than those specified, with the exception of cables provided by Teledyne DALSA as replacement parts, may result in increased emission or decreased immunity of the Rad-ikon Detector.

Static precautions

Observe proper ESD/ static control procedures when handling system components. The use of a properly grounded wrist strap is highly recommended.



Installation Precautions

Never connect or disconnect cables while the power to the detector is on. Damage to the detector electronics might occur if the cables are connected and/ or disconnected while the detectors power is on.

Service by Qualified Personnel Only

This equipment is to be installed by a qualified technician only. The system can only be used in conjunction with a properly installed X-ray source with the appropriate shielding and a properly configured computer workstation that meets the minimum system requirements discussed later in this manual.

Environmental Specifications

Temperature	
- Operating	+10..+40 °C
- Transport & Storage	-10..+55 °C
Humidity (non-condensing)	
- Operating	20%..80%
- Transport & Storage	20%..80%
Shock	25G (6ms)
Vibration	1G (10-150Hz)

Note: For transport and storage, the standard product packaging is assumed to be in place which includes a sealed anti-static shield bag.

Detector Maintenance

Before performing any of the following operations, make sure that the power to the detector is switched OFF.

Protecting the Detector Front Cover

The imaging area should be treated with care, as scratches or particles in this area may produce artifacts in the X-ray image.

Cleaning the Detector Body and Front Cover

The detector body and front cover can be cleaned with a mild, non-abrasive cleanser such as isopropyl alcohol. Place a small amount of cleanser on a soft cloth and rub gently over the detector body surface. Wipe off with a clean soft cloth. Do not use any harsh cleansers or solvents that may damage the paint or other finishes on the detector.

In the event of detector exposure to bio-hazardous materials, proper cleaning procedures should be undertaken prior to removal, maintenance or return of the detector.

Calibration

To have the best image performance, the raw image data generated by the detector should be corrected at the host by using a flat field (offset and gain) correction. As the offset (dark) calibration signal depends (amongst others) on ambient temperature conditions of the detector, it is commonly accepted good practice to generate these calibration images frequently at times that the X-ray source is switched off. It is recommended to re-calibrate the gain correction image at least once per year, at least when e.g. the X-ray tube is exchanged or anything changes in the X-ray imaging geometry (e.g. the distance between the X-ray source and the detector).

The detector can contain deviating pixels. To have the best possible image quality it is advised to perform a defect pixel correction in the host system. It is recommended to create a defect pixels calibration image at least every year, or more frequently in case of heavy use.

To verify if the detector still operates according specification it is advised to measure on regular base the following performance parameters of the detector: dark reference, noise performance, flatfield reference, saturation dose and MTF performance.

2

The Rad-icon Detector

A full description of the features and functional specification of the Rad-icon 2022 detector can be found in the latest product specification or datasheet. Please contact sales.rad-icon@TeledyneDALSA.com or visit www.TeledyneDALSA.com/ndt/ for information on how to obtain the latest datasheet or other product documentation.

Detector highlights

Key Features

- Latest generation CMOS technology (6th generation) enables even lower noise and power consumption
- Unmatched image quality at low x-ray dose
- 2064 x 2236 pixel resolution, 99 um pixel pitch, active area 204 mm x 221 mm
- 14-bit A/ D conversion
- No measureable image lag
- Up to 30fps at full resolution, 60fps in 2x2 binned mode
- Cameralink Full data interface
- GdOS scintillator

Programmability

- Programmable exposure time, line rate and trigger modes.

Typical Applications

- Non Destructive Testing
- Electronics Inspection
- Computed Tomography (CT)
- X-ray Crystallography

Setting up the Detector

Detector Connectors and Cables

This detector uses the following connectors.

- Two 26 pin High Density Mini-D Ribbon (MDR) connectors for data signals
 - Camera Link cables MDR↔SDR or MDR↔MDR.
For instance: 1MD26-R560-00C-500
- One 2-pin Lemo connector for power
 - Lemo EGG.2B.302
 - Mating connector:
straight type: FGG.2B.302.CLAD52
- One 4-pin Lemo connector for triggering
 - Lemo EGG.2B.304
 - Mating connector:
straight type: FGG.2B.304.CLAD52

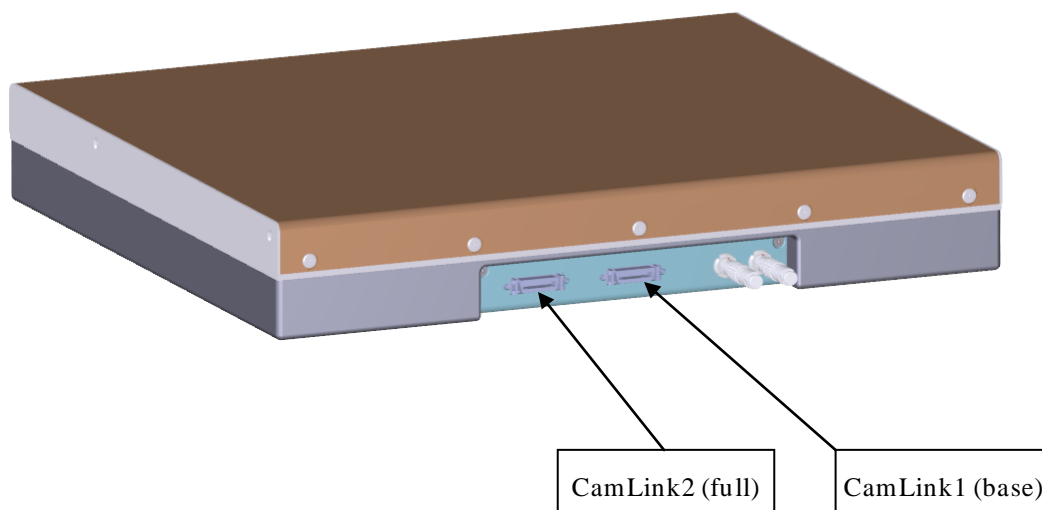

Camera Link Connector

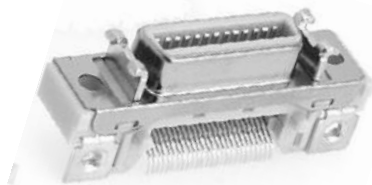

26-Position High Density Mini-D Ribbon Female Plug

Chassis is connected to ground. Communication is via the CameraLink UART interface.

Detector Status LED

The detector is equipped with a green LED used to display the status of the detector’s operation. The table below summarizes the operating states of the detector and the corresponding LED state.

	Color of Status LED	Meaning
1	Green	Detector is operational
2	Off	No power

Power Connector

Power Connector

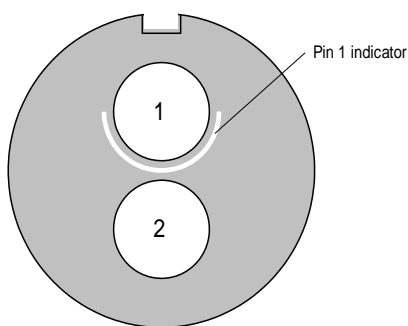

Rear View Plug

	Description
1	Supply voltage (+12V/ 3A)
2	Ground Shielding (chassis)

The detector requires a single voltage input (+12V/ max 3A). There is a protection for misconnection, via a resettable fuse. When the fuse has been activated (isolating),

power cycling will return it to conductive state again thus restoring normal operation (assuming power has been properly applied).

The voltage range which can be applied is 11V – 26V.



WARNING: When setting up the camera's power supplies follow these guidelines:

- Apply the appropriate voltages.
- Keep leads as short as possible in order to reduce voltage drop. The voltage level at the product power connector should be within the range mentioned in the datasheet.
- Use high-quality linear supplies of SELV type and EN 60601-1 compliant.

Note: If your power supply does not meet these requirements, the detector performance specifications cannot be guaranteed.

Trigger Connector

The trigger circuitry inside the detector is shown in the figure below.

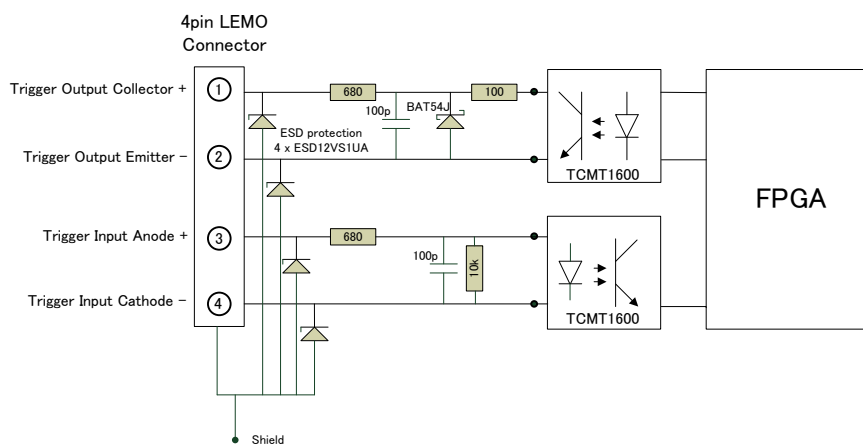

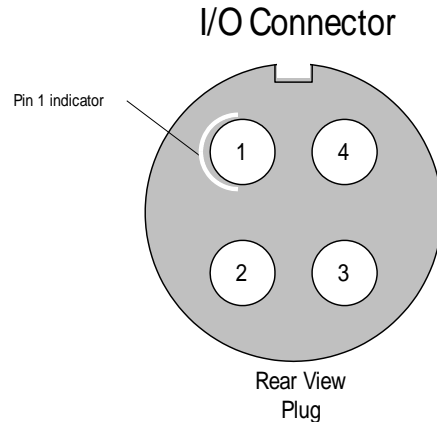

Description		
1	Out	optocoupler collector with 680R series resistor (note 1)
2	Out	optocoupler emitter
3	In	optocoupler anode with 680R series resistor (note 2)
4	In	optocoupler cathode
Shielding (chassis)		

Note 1 (photodiode side):

The optocoupler photodiode output is able to sink 10mA current in non-saturated condition. Absolute maximum voltage is 15V. Do not apply a voltage with reversed polarity.

Note 2 (Led side):

The recommended LED forward current is 5mA, which is obtained with 5V input voltage. Absolute maximum input voltage is 10.0V. Do not apply an input voltage with reversed polarity.

Setting up the Detector

Camera Link frame grabber card

To use the provided software tools a Teledyne DALSA frame grabber is needed. The Xcelera-CL PX4 Full is recommended.

Install the frame grabber driver and insert the card before connecting the detector.

Ground the detector

Use an appropriate ground connection.

Connect trigger cable

When using the detector in snapshot mode, connect the trigger cable to the detector.

Connect Camera Link cable

Connect the frame grabber cables (2ea) from the detector to the computer. Secure the Mini-D ribbon connectors to the detector. **The cable length should be limited to 7m.**

Connect power cable

Connect a power cable from the detector to a +12V power supply.

Software Installation

Refer to the next chapter for instructions on installing and running the detector.

4

Installing the Rad-icon Detector

To evaluate a device like the Rad-icon 2022, you will need to install SaperaLT with CamExpert and the CameraLink frame grabber to grab images. This software is compatible with Windows 64-bit systems but can also be used with 32-bit Windows.

Installing

Operating Systems Support

The current released framework supports up to Windows 10.

Obtain software

CD

Check the CD that shipped with your detector for installation files for CamExpert, the frame grabber driver and/ or the ShadoCam software. To obtain the latest versions, or software for a newer operation system, it may be necessary to go to the Teledyne DALSA website for the latest updates.

Website

Visit the Teledyne DALSA website to download the latest free version of the Sapera LT SDK, including the CamExpert image viewer:

<http://www.teledynedalsa.com/imaging/products/software/sapera/lt/download/>

The download is free after filling out the on-line registration form. Make sure to select “Full SDK” as your download option.

Sapera LT and CamExpert Installation

A link to download the software will be emailed to you after submitting the application. Complete the download process and run the installation file (e.g. “SaperaLT80xSDKSetup.exe”).

CamExpert is an image viewer designed to evaluate your detector. The Sapera SDK is a set of development tools and documentation for creating your own software for interfacing to the product. Please download the appropriate materials and follow the instructions that are part of that download.

The Sapera SDK installation also contains a large number of helpful example projects to help you get started with integration the detector into your own application software. For additional examples or a ccf (camera configuration file) specific to the Rad-icon 2022 detector please contact our support team at the contact info listed on page 2 of this manual.

Camera Link frame grabber configuration files

The configuration files for the Xcelera-CL PX4 Full frame grabber can be sent on request. This frame grabber requires multiples of 16 as horizontal resolution. Therefore the following configurations are available:

- Full resolution, no binning (2064 x 3096), 4 taps
Custom configuration:
 - 2Taps, 2 channels:
Tap/ Channel 1: Right to Left, Top to Bottom
Tap/ Channel 2: Left to Right, Top to Bottom
Tap/ Channel 3: Right to Left, Bottom to Top
Tap/ Channel 4: Left to Right, Bottom to Top
- Binning mode (1032 x 1548), 4 taps
Custom configuration:
 - 2Taps, 2 channels:
Tap/ Channel 1: Right to Left, Top to Bottom
Tap/ Channel 2: Left to Right, Top to Bottom
Tap/ Channel 3: Right to Left, Bottom to Top
Tap/ Channel 4: Left to Right, Bottom to Top

Note: because the Rad-icon 2022 detector is scanned in “butterfly” mode (top and bottom row of tiles are scanned simultaneously), the total height in CamExpert needs to be configured as twice the number of rows in the top tiles; hence 3096. The actual format of 2064 columns by 2236 rows is defined in the ROI settings tab.

Connecting

1. After the installation is complete, plug in the detector's communication cable.
2. Power up the detector.

Communication

Settings can be changed in the camera by serial communication.

Functions available include:

- Controlling basic detector functions such as readout mode, sync mode, etc.
- Generating a test pattern

The serial interface uses a simple ASCII-based protocol.

Open the Sopera Configuration tool (installed with Teledyne DALSA SoperaLT software) and map the Physical Port of the frame grabber card to one of the available COM ports. You will be asked to reboot the system after saving settings.

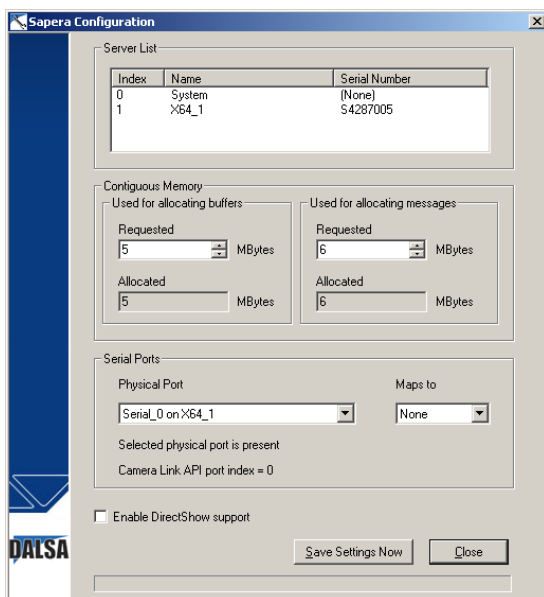

Serial communication can be made using following settings:

Baud rate: 115200

Data bits: 8

Parity: None

Stop bits: 1

Flow control: none

Acquiring Images

The CamExpert software can be started to acquire images.

Select the correct device and check the video status to verify if the detector is connected to the system. *Pixel Clock*, *Frame Valid* and *Line Valid* signals all have to be present:

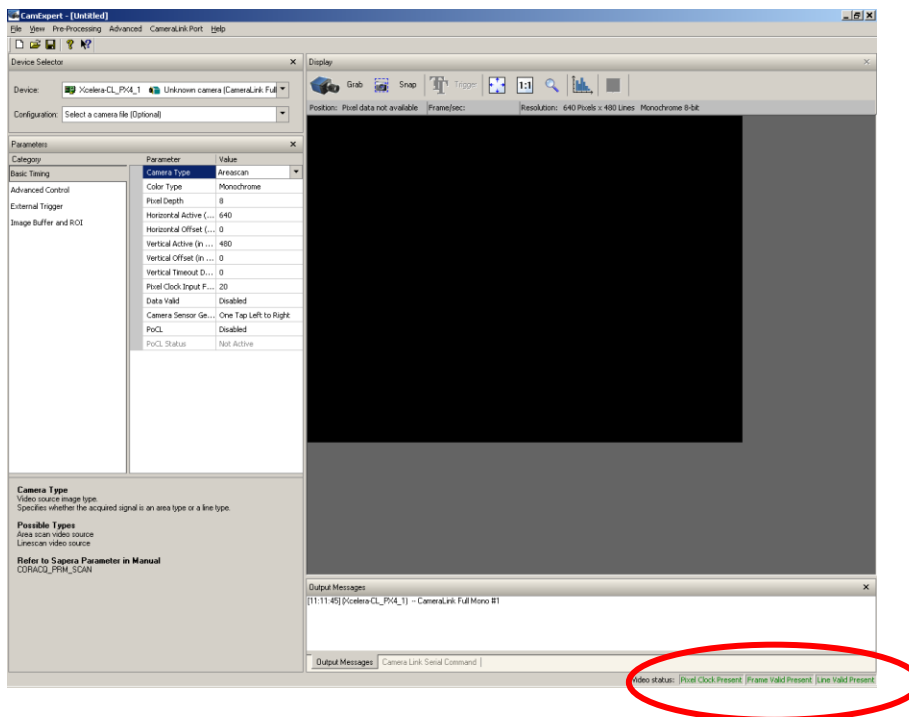

Load the correct frame grabber configuration file (available on request).

The settings can be saved as a .ccf file and recalled.

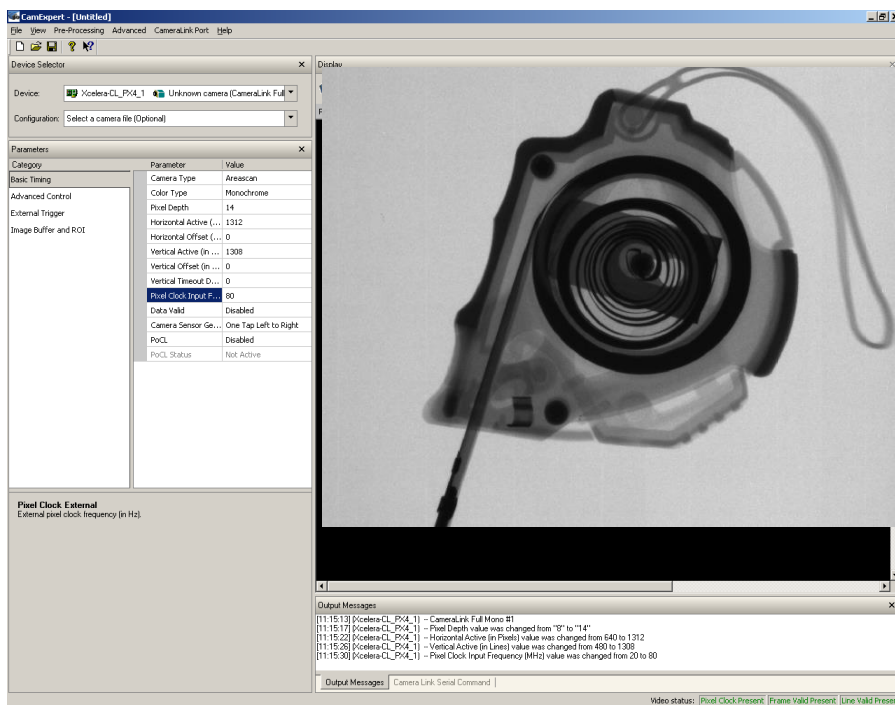

The user has the option to either snap an image or to grab multiple images. Snapping an image produces a single frame, whereas the grabbing process generates multiple frames by operating in a continuous mode.

To snap an image:

Click the *Snap* button. The detector has now snapped a single frame. The image appears in the GUI window.

To grab multiple images:

Click the *Grab* button. The detector is now armed and ready to acquire images in continuous mode.

To stop a *Grab* process the user must press the *Freeze* button. After the *Freeze* button is pressed the detector ignores any additional triggers and no additional images are acquired.

The detector is configured with an array of 2 x 2 sensors, as shown in the following diagram:

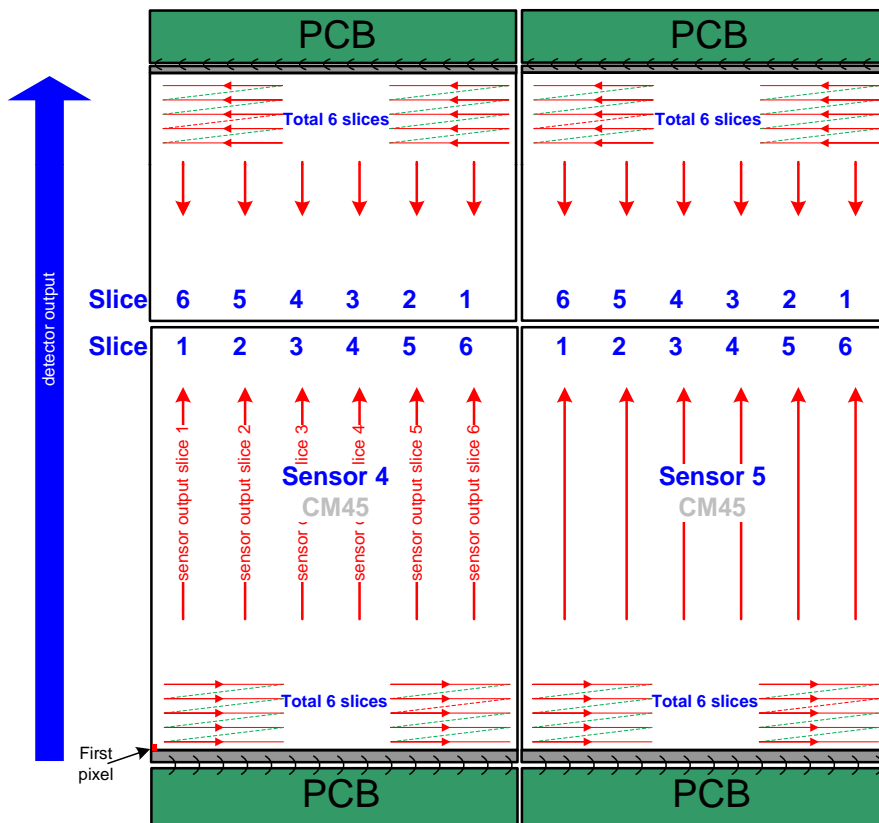

The sensors are stitched within one pixel dimension; therefore a (optional) butting column is inserted in the image.

- On position 1032 (counting from 0) a dummy column may be inserted.

A butting row is NOT inserted. If required, this should be done in software after the image is acquired.

Functional Description

Operation modes

The detector has 3 different operation modes:

User Mode

The detector starts by default in User Mode. In User Mode all features can be controlled except for the maintenance and production related features. See paragraph [Detector Operation Mode](#) for more details.

Maintenance

In Maintenance Mode image acquisition is possible but not recommended. See paragraphs [Detector Operation Mode](#) and [Set Detector Mode](#) for more details.

Production

This mode is password protected and reserved for production items only. See paragraph [Detector Operation Mode](#) for more details.

Full Well selection

The detector is equipped with a switchable pixel full well capacity to achieve the highest performance over a wide dose range. Please refer to the datasheet for exact full well capacity values. See chapter [Full Well selection](#) for more command details.

Readout modes

X-ray source

The detector can be used in combination with a DC X-ray source or a pulsed X-ray source. The following paragraphs explain the detector operation for the different X-ray sources.

Detector operation with pulsed X-ray source

Figure 1 depicts the detector operation in case of a pulsed X-ray exposure.

The figure shows the array row read-out as a function of time. The frame integration period is indicated in light green and the actual image-capture interval is marked with the dark green rectangle. The frame containing the image information is marked blue.

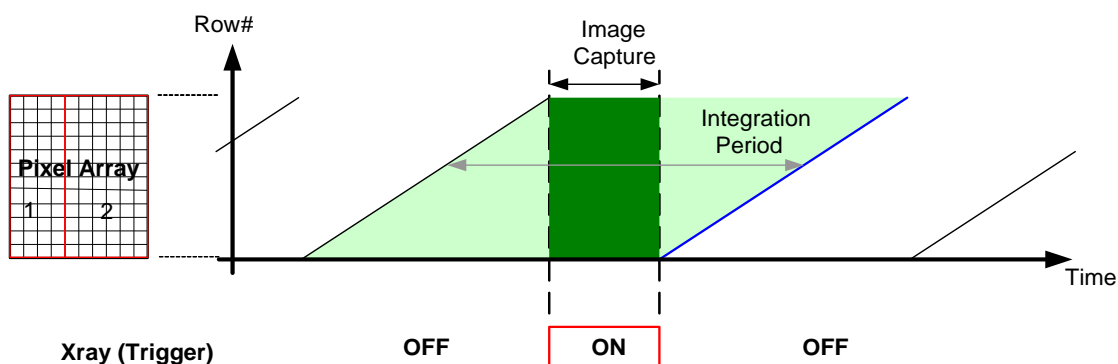

Figure 1, Pulsing the X-ray source during extended frame-blanking interval

The period of time in between successive frame read-outs (dark green) is used to activate the pulsed X-ray source. The width of this time-period can either be programmed via the detector command interface by setting the exposure time or it can be controlled by the “TRIGGER-IN” input signal (active high time).

Synchronization of the X-ray source with the detector timing can be realized via the master/ slave synchronization option as included in the detector.

In slave mode the detector synchronizes the start of the vertical blanking window (dark green window) with the rising edge of the applied synchronization signal. When operated in master mode, the detector delivers a positive going synchronization signal to the outside world for synchronization of the X-ray source. The rising edge of the synchronization signal determines the start of the vertical blanking window.

Detector operation with DC X-ray source

Figure 2 depicts the detector operation under DC X-ray conditions. The period of time in between the row reset and row read-out determines the effective exposure time.

As the next figure illustrates, exposure times shorter than the frame read-out time are possible. Although not illustrated, exposure times exceeding the frame read-out time are possible as well, but impact the maximum achievable frame-rate.

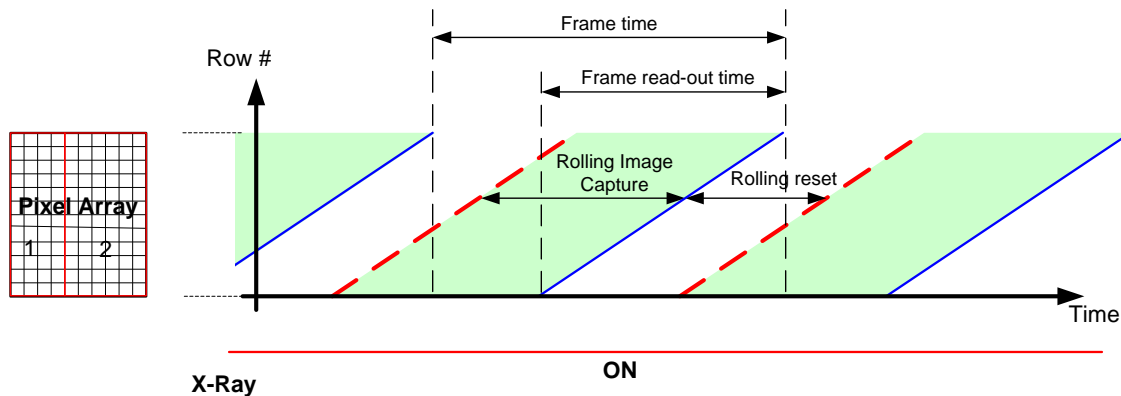

Figure 2, Rolling shutter operation with DC X-ray source

Readout modes

The image of the detector can be read-out in several different modes:

- Full Field of View, non binned, High Full Well: Max. framerate is 30FPS.
- Full Field of View, non binned, Low Full Well: Max. framerate is 30FPS.
- Full Field of View 2x2 Binning, High Full Well. This results in a two times higher framerate, 60FPS
- Full Field of View 2x2 Binning, Low Full Well. This results in a two times higher framerate, 60FPS

The split between two vertical image halves does not contain a dummy row. A dummy row has to be inserted manually after image is saved. The location of the dummy row should be inserted in row 1548 (counting from row 0).

In the horizontal direction a dummy column can be inserted in Column 1032 (counting from 0).

Synchronization modes

The detector has three synchronization modes. The detector can operate in Master/ Slave configuration.

Free running mode, Full Field of View

The detector is Master and will give a trigger output indicating the time moment where x-ray can be flashed in (See Figure 3).

The frame rate and x-ray-window is programmable by Extended Exposure setting (see paragraph [Extended Exposure / X-ray Window time](#) for command details).

Extended Exposure is often also referred to as X-ray Window. The unit of Extended Exposure / X-ray Window is millisecond.

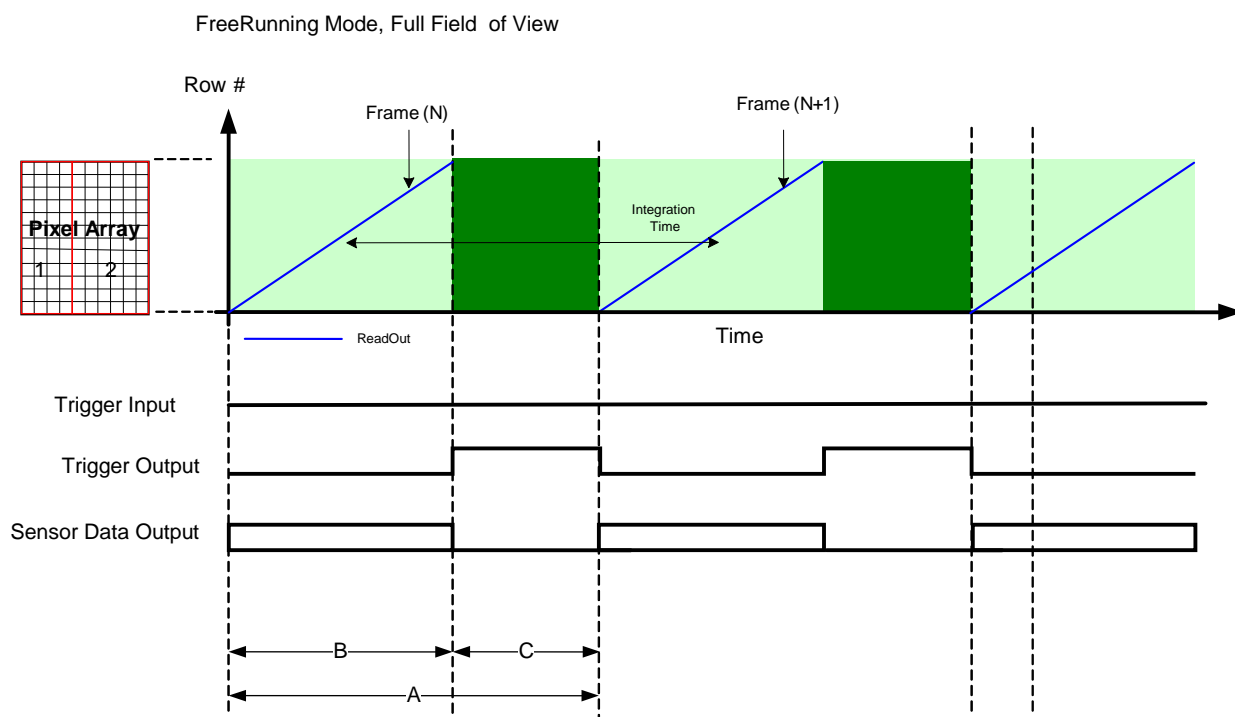

Operation mode:	Full Field of View, non binned	Full Field of View, 2x2 Binning
1/A: Frame rate	≤ 32 FPS	≤ 64 FPS
A: integration time	≥ 31 ms	≥ 15.5 ms
B: readout time	30 ms	15 ms
C: Extended Exposure / Xray window	A - B	A - B

Figure 3, Timing diagram 'FreeRunning, Full Field of View'

External trigger mode, Full Field of View

The detector is slave and will start readout after the falling edge of the external trigger input signal (See Figure 4). Trigger out is indication of the X-ray Window. The minimum Trigger high time should be 1 ms.

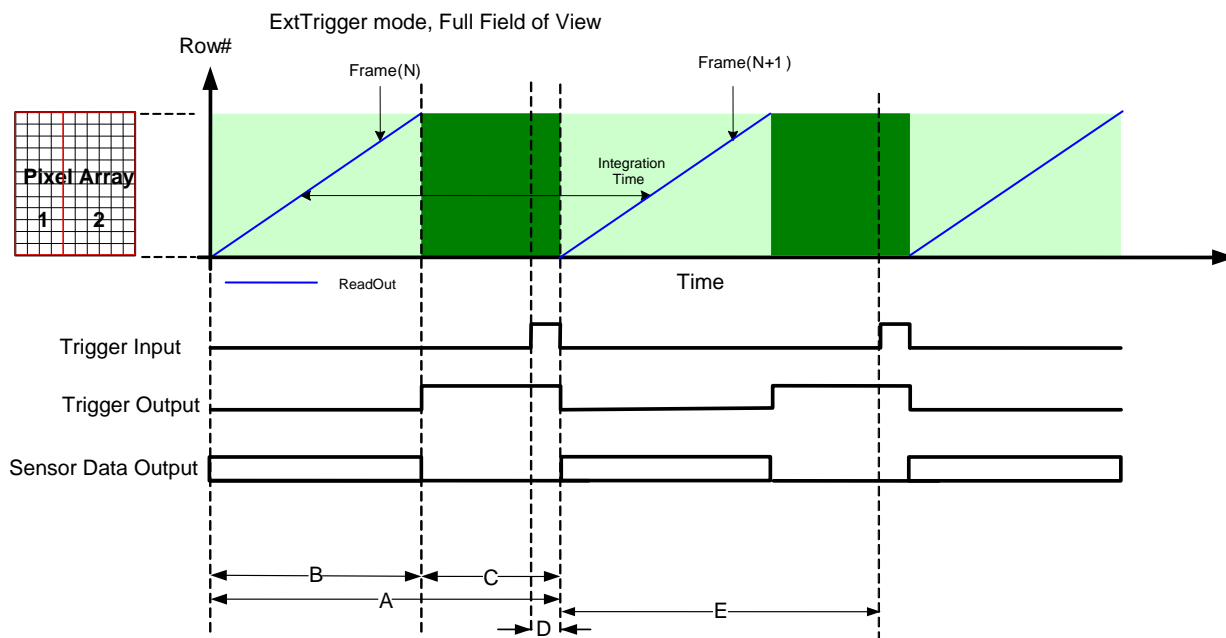

Operation mode:	Full Field of View, non Binned	Full Field of View, 2x2 Binning
1/A: Frame rate	≤ 31 FPS	≤ 60 FPS
A: integration time	≥ 32 ms	≥ 16.5 ms
B: readout time	30 ms	15 ms
C: Xray window	A - B	A - B
D: Trigger active high	> 1 ms	> 1 ms
E: Trigger active low	> B	> B

Figure 4, Timing diagram 'ExtTrigger Mode, Full Field of View'

Note on Trigger input:

To have maximum frame rate, the trigger input “active-high” time should not be more than 1ms.

Note on Trigger output:

The trigger input and output are optically isolated from the outside world. For the trigger output this means that the optocoupler is acting as a switch: When trigger output is active (see diagrams above) then the switch is conducting.

Snap shot mode

The detector is slave and will start following sequence when trigger input signal is applied:

- Start of trigger (rising edge) → Reset operation of sensor
- After reset → Integration period. Trigger out is indication of the integration period.
- End of trigger (falling edge) → Readout sensor.

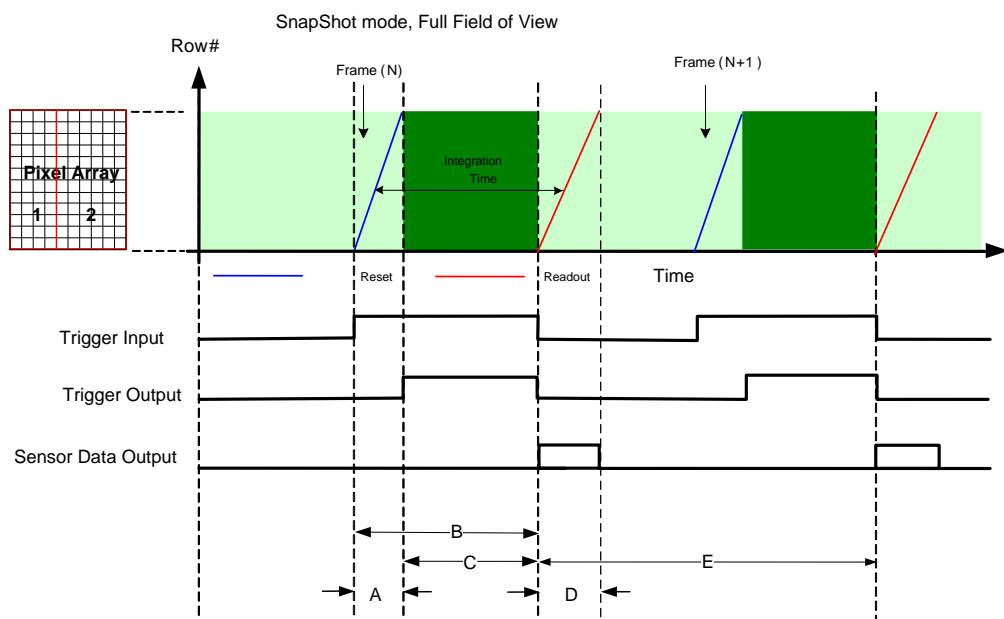

Operation mode:	Full resolution	Binning 2x2
A: readout/reset time	30 ms	15 ms
B: Trigger active high = integration time	> 31 ms	> 15.5 ms
C: x-ray window	B - A (trigger active high - reset time)	B - A (trigger active high - reset time)
D: Trigger active low	> 31 ms	> 15.5 ms

Figure 5, Timing diagram 'Snapshot Mode, Full Field of View'

Shuttering

Please note: the Rad-icon Detector does not have a shuttering mechanism built into the detector. The detector can be operated quite normally with a continuous beam X-ray source, however there can be motion blur associated with continuous beam imaging. In the case that pulsed X-ray operation is required, the X-ray pulse must be carefully timed so that X-rays from the pulse are not incident on the detector during readout. Incorrect use will cause imaging artifacts that show up as very uneven illumination within the images.

Diagnostics

Test Image

For diagnostic purpose the following test images can be selected:

- Sensor Fixed Pattern (generated in CMOS sensor)
- Horizontal Wedge (generated in system FPGA)
- Vertical Wedge (generated in system FPGA)
- White (generated in system FPGA)
- Alternating black/ white (generated in system FPGA)
- Increasing value each frame (generated in system FPGA)
- Constant pixel value (generated in system FPGA)

See paragraph [Source of Image Data](#) for more details.

Firmware version, Model name and serial number

The detector does have EEPROM and FLASH memory on board.

In the EEPROM the following information is stored:

- FW revision. Version of the firmware on the processing board can be read back.
- HW revision. The hardware revision can also be read back.
- Detector settings. Settings (voltages, timing parameters) can also be read back.
- Modelname and serial number are stored in EEPROM.

See paragraphs [Get Detector Manufacturers Name](#), [Get Detector Model Name](#), [Get Detector Serial Number](#), [Detector Firmware Version](#) for more details.

Power saving

The detector has a power saving mode called Standby. In Standby mode the power consumption is reduced by switching off the sensors. This enables a fast recovery time. The power consumption is reduced by 10 watts. See paragraph Detector Power Mode for more details. The startup time from Standby mode to PowerOn mode is less than 1s. The power consumption in Standby mode is less than 50% of the power consumption during PowerOn mode.

Please also see Dark Current after Extended Standby.

5

Commands

When entering commands, remember that:

A carriage return <CR> ends each command.

- A space or multiple space characters separate parameters. Tabs are invalid parameter separators.
- Upper and lowercase characters are accepted
- The backspace key is supported
- The ">" is used exclusively as the last character sent by the detector.

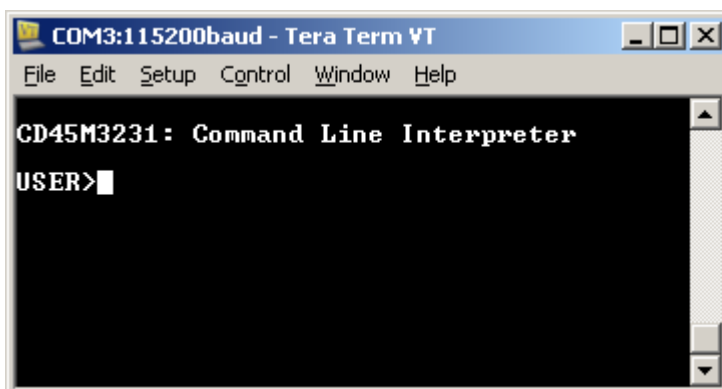

The following parameter conventions are used in the manual:

- i = integer value
- f = real number
- m = member of a set
- s = string

Example: to return the current detector settings

gcp <CR>

Help

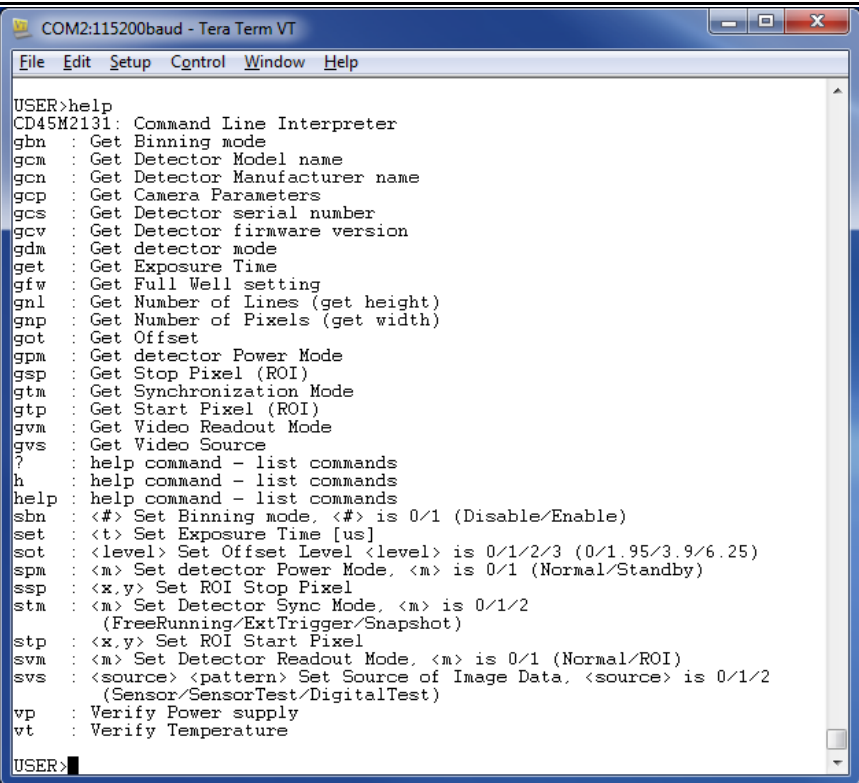
Command Name	help or h of ?
Purpose	For quick help, the camera can be queried seeking list of all available commands and parameters.
Access Type	Read Only
Syntax	help <CR>
Parameter	None
Return Value	 <pre> COM2:115200baud - Tera Term VT File Edit Setup Control Window Help USER>help CD45M2131: Command Line Interpreter gbn : Get Binning mode gcm : Get Detector Model name gcn : Get Detector Manufacturer name gcp : Get Camera Parameters gcs : Get Detector serial number gcv : Get Detector firmware version gdm : Get detector mode get : Get Exposure Time gfw : Get Full Well setting gnl : Get Number of Lines (get height) gnp : Get Number of Pixels (get width) got : Get Offset gpm : Get detector Power Mode gsp : Get Stop Pixel (ROI) gtm : Get Synchronization Mode gtp : Get Start Pixel (ROI) gvm : Get Video Readout Mode gvs : Get Video Source ? : help command - list commands h : help command - list commands help : help command - list commands sbn : <#> Set Binning mode, <#> is 0/1 (Disable/Enable) set : <t> Set Exposure Time [us] sot : <level> Set Offset Level <level> is 0/1/2/3 (0/1.95/3.9/6.25) spm : <m> Set detector Power Mode, <m> is 0/1 (Normal/Standby) ssp : <x,y> Set ROI Stop Pixel stm : <m> Set Detector Sync Mode, <m> is 0/1/2 (FreeRunning/ExtTrigger/Snapshot) stp : <x,y> Set ROI Start Pixel svm : <m> Set Detector Readout Mode, <m> is 0/1 (Normal/ROI) svs : <source> <pattern> Set Source of Image Data, <source> is 0/1/2 (Sensor/SensorTest/DigitalTest) vp : Verify Power supply vt : Verify Temperature USER> </pre>
Example	

Identification

Get Detector Parameters

Command Name	gcp
Purpose	To identify the detector and read current settings.
Access Type	Read Only
Syntax	gcp<CR>
Parameter	None
Return Value	List of detector identity values and configuration settings
Example	<p>User Enters -- gcp<CR></p> <p>Detector Returns – CD45M2231: Model Name 135.00.00.003.003: Firmware Version 1234: Serial number 0: Normal Power Mode 0 0: Image Source 0: Extended Exposure Value [ms]</p>

Get Detector Manufacturers Name

Command Name	gcn
Purpose	To identify the manufacturer of the detector
Access Type	Read Only
Syntax	gcn<CR>
Parameter	None
Return Value	Teledyne Dalsa: Manufacturer
Example	<p>User Enters – gcn<CR></p> <p>Detector Returns – Teledyne Dalsa: Manufacturer</p>

Get Detector Model Name

Command Name	<code>gcm</code>
Purpose	To identify the particular model of the detector
Access Type	Read Only
Syntax	<code>gcm<CR></code>
Parameter	None
Return Value	nnnnnn: Model Name
Example	User Enters – <code>gcm<CR></code> Detector Returns – CD45M2231: Model Name

Get Detector Serial Number

Command Name	<code>gcs</code>
Purpose	To identify the detector serial number
Access Type	Read Only
Syntax	<code>gcs<CR></code>
Parameter	None
Return Value	nnnnnn: Serial Number
Example	User Enters – <code>gcs<CR></code> Detector Returns – 123: Serial Number

Detector Firmware Version

Command Name	<code>gcv</code>
Purpose	To identify which firm ware is programmed to the detector
Access Type	Read Only
Syntax	<code>gcv<CR></code>
Parameter	None
Return Value	<code>vvv.w w .xx.yyy.zzz: Firm ware Version</code>
Example	User Enters – <code>gcv<CR></code> Detector Returns – <code>135.00.00.003.003: Firm ware Version</code>

Detector Operation Mode

Set Detector Mode

Command Name	sdm
Purpose	To configure the detector to work in User, Maintenance or Production mode.
Access Type	Write Only
Syntax	sdm <i1> <i2><CR>
Parameter	Where <i1> is 0 : (User) OR 1 : (Maintenance) OR 2 : (Production) <i2> is 4 digit password
Default value	0: User
Return Value	None
Example	

Get Detector Mode

Command Name	gdm
Purpose	To determine whether the current mode of the detector is in user, maintenance or production mode
Access Type	Read Only
Syntax	gdm <CR>
Parameter	None
Return Value	“0:User”, “1: Maintenance” or “2: Production”
Example	User Enters – gdm<CR> Detector Returns – 0: User

Detector Power Mode

Set Detector Power Mode

Command Name	spm
Purpose	To switch the detector between normal mode and power saving mode.
Access Type	Write Only
Syntax	spm <i><CR>
Parameter	Where <i> is 0 : (Normal) OR 1 : (Standby)
Default Value	0: Normal
Return Value	None
Example	

Get Detector Power Mode

Command Name	gpm
Purpose	To determine whether the detector is in normal or power saving standby mode.
Access Type	Read Only
Syntax	gpm<CR>
Parameter	None
Return Value	“0: Normal” or “1: Standby”
Example	User Enters – gpm<CR> Detector Returns – 0: Normal

Source of Image Data

Set Source of Image Data

Command Name	svs
Purpose	To switch between image acquisition chains.
Access Type	Write Only
Syntax	svs <i1> <i2><CR>
Parameter	<p>Where <i1> is</p> <p>0 : (Sensor Data) OR 1 : (Sensor test pattern) OR 2 : (digital test pattern gen)</p> <p>Where <i2> is</p> <p>for <i1 = 0></p> <p>0: Low Full Well 1: High Full Well</p> <p>for <i1 = 1></p> <p>0: Sensor Fixed Pattern (fixed value of 0x3D0A)</p> <p>for <i1 = 2></p> <p>0: Pixel counter 1: Line counter 2: Fixed value of 3FFF 3: Fixed value of 3FFF 4: Alternating 3FFF and 0000 5: Frame counter 6: Constant value of 0x00BF 7: Constant value of 0x00BF</p>
Default Value	0 0: Sensor Data with Low Full Well
Return Value	
Example	

Get Source of Image Data

Command Name	<code>gvs</code>
Purpose	To determine the current source of image data from the detector
Access Type	Read Only
Syntax	<code>gvs<CR></code>
Parameter	None
Return Value	<o1> <o2>: Image source See <code>svs</code> command for <o1> and <o2>
Example	User Enters – <code>gvs<CR></code> Detector Returns – 00: Image source

Full Well Selection

Get Full Well

Command Name	gfw
Purpose	To determine the current full well selection
Access Type	Read Only
Syntax	gfw<CR>
Parameter	None
Return Value	“1: High Full Well” or “0: Low Full Well”
Example	User Enters – gfw<CR> Detector Returns – 1: High Full Well

Note: to select a full well use the svcs command.

Detector Synchronization Mode

Set Detector Synchronization Mode

Command Name	stm
Purpose	To prepare detector to operate in one of the synchronization modes.
Access Type	Write Only
Syntax	stm <i>
Parameter	Where <i> is 0 : (Free running) OR 1 : (External Trigger) OR 2 : (Snapshot)
Default Value	0: Free running
Return Value	None
Example	

Get Detector Synchronization Mode

Command Name	gtm
Purpose	To determine in which synchronization mode is the detector in.
Access Type	Read Only
Syntax	gtm <CR>
Parameter	None
Return Value	“0: Free Running”, “1: External Trigger” or “2: Snapshot mode”
Example	User Enters – gtm<CR> Detector Returns – 0: Free Running

Detector Readout Mode

Set Detector Readout Mode

Command Name	svm
Purpose	To readout different data resolutions at different frame rates.
Access Type	Write Only
Syntax	svm<i>
Parameter	Where <i> is 0 : (Full Resolution) OR 1 : (flexible ROI)
Default Value	0: Full Resolution
Return Value	None
Example	

Note: Command only available in PRODUCTION MODE
ROI mode not implemented in current revision

Get Detector Readout Mode

Command Name	gvm
Purpose	To determine the current readout mode.
Access Type	Read Only
Syntax	gvm<CR>
Parameter	None
Return Value	“0: Full Resolution” or “1: Flexible ROI”
Example	User Enters – gvm<CR> Detector Returns – 0: Full Resolution

Set Detector Binning Mode

Command Name	sbn
Purpose	Set Binning Mode
Access Type	Write Only
Syntax	sbn<i><CR>
Parameter	Where <i> is 0: (binning disabled) OR 1: (binning enabled)
Default Value	0: binning disabled
Return Value	None
Example	

Get Detector Binning Mode

Command Name	gbn
Purpose	Get Binning Mode
Access Type	Read Only
Syntax	gbn<CR>
Parameter	None
Return Value	“1: Binning enabled “ or “0: Binning disabled”
Example	User Enters – gbn<CR> Detector Returns – 0: Binning disabled

Extended Exposure / X-ray Window time

Set Extended Exposure Time

Command Name	set
Purpose	Extended Exposure time, defines the vertical blanking interval
Access Type	Write Only
Syntax	set<i>
Parameter	Where i = 0 to 65535 [ms]
Default Value	0
Return Value	None
Example	

Note: In case CamExpert displays a video transmission error (insufficient bandwidth...), we recommend setting the Extended Exposure to 10-20ms between frames in order to allow the host computer to catch up.

Get Exposure Time

Command Name	get
Purpose	Extended Exposure time, defines the vertical blanking interval
Access Type	Read Only
Syntax	get<CR>
Parameter	None
Return Value	<time>: Extended Exposure Value [ms];
Example	User Enters – get<CR> Detector Returns – 30: Extended Exposure Value [ms]

Offset

Set Offset

Command Name	sot
Purpose	To set black level offset of the sensor
Access Type	Write
Syntax	sot <i><CR>
Parameter	Where i = 0,1,2,3 0: Offset 0 % of full scale 1: Offset 1.95 % of full scale 2: Offset 3.9 % of full scale 3: Offset 6.25 % of full scale
Default Value	1
Return Value	None
Example	

Get Offset

Command Name	got
Purpose	To determine the current black level offset setting
Access Type	Read
Syntax	got<CR>
Parameter	None
Return Value	“0: Offset 0 pct”, “1: Offset 1 pct 95”, “2: Offset 3 pct 9” or “3: Offset 6 pct 25”
Example	User Enters – got<CR> Detector Returns – 0: Offset 0 pct

Dark Current after Extended Standby

A first image acquired after long time in standby mode might contain unwanted signal. It is recommended to read and discard one or more images at the start of a measurement sequence.

Mode switches

A first image acquired after a change of mode (binning, video, synchronization or trigger) might contain unwanted signal. It is recommended to read and discard one or more images at the start of a new measurement sequence.

When switching from free running to any other mode the detector may output still one image because the timing sequence was already started.

Error Handling

When the prompt is returned by the detector, the detector is ready to receive a new command.

When an unknown command is received the detector returns the entered command followed by three question marks, e.g. 'Warnng: bcv???'.

When an incorrect number of parameters is send to the detector, the detector will respond with the following response 'Error: Incorrect number of parameters'.

When an incorrect value is send to the detector, the detector will respond with a response like 'Error: Invalid Image Source'.

6

Mechanical Interface

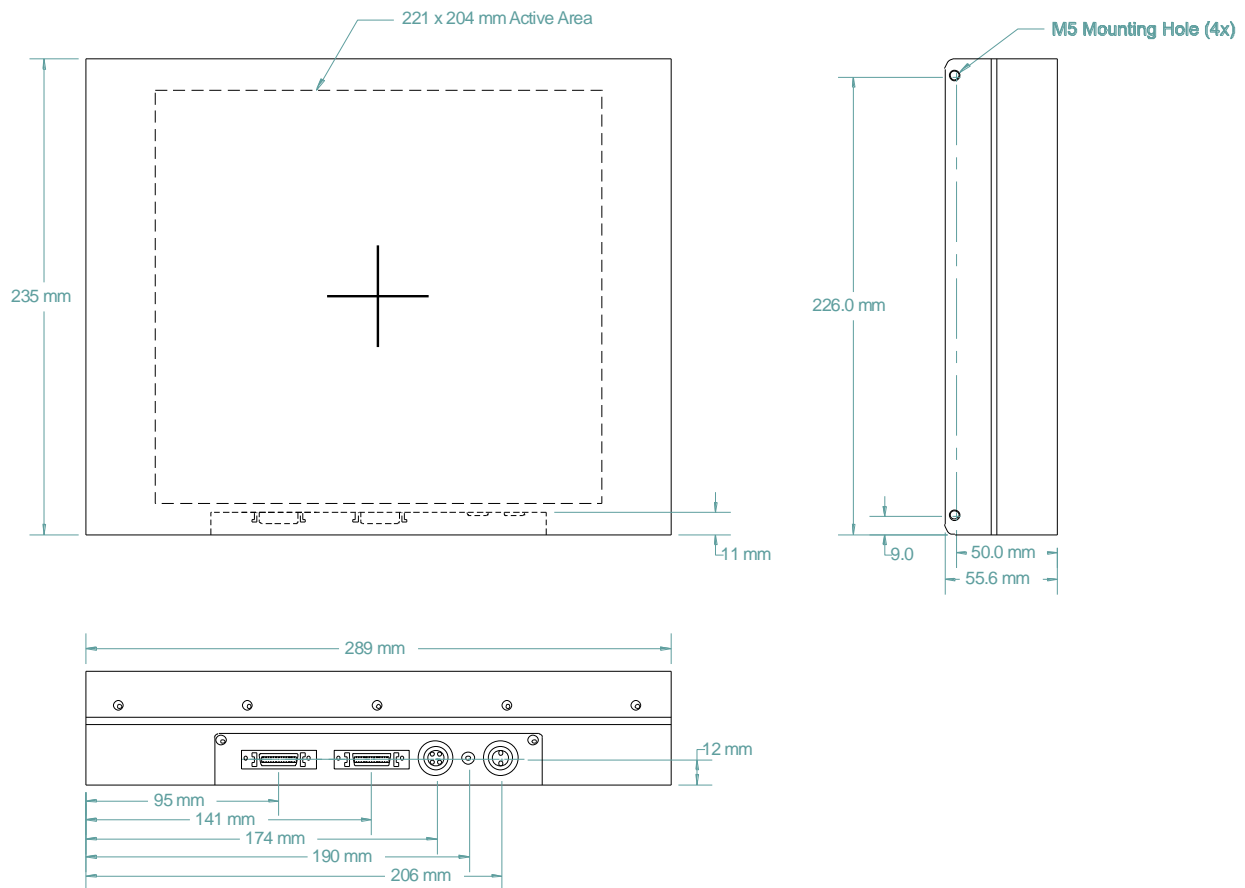

Appendix A

Revision History

Revision Number	Change Description	Revision Date
01	Draft release	June 29, 2015
02	Updated connectors, software, mechanical drawing	Dec. 30, 2015